

Important Booth Setup Reminders

Furnishings, electricity, carpeting

Furnishings, electricity, internet or floor coverings are NOT included with the booth

Standard In-Line Booth Equipment



Back Drape – 8'3" feet from the floor to the top of the drapery. **No signage is allowed above 8'3" or the top of the drapery.**

Side Drapes – 3 feet high from floor to the top of the drapery

Company ID Sign – 7" high by 44" wide (white background with black lettering)

Booth Set-Up

A standard booth is any booth 10' in depth.

Booths 10' in depth may be built to a **height NOT to exceed 8' 3" including an identification sign.**

The side walls of booths 10' in depth may extend 5' from the back wall at a height of 8'3" then must drop down to a height of 4' as not to block the sight lines of neighboring exhibitors. All solid opaque structures or exhibit materials over 4' in height are to be confined to within 5' of the back wall of the booth to avoid obstructing the view of adjoining exhibitors.

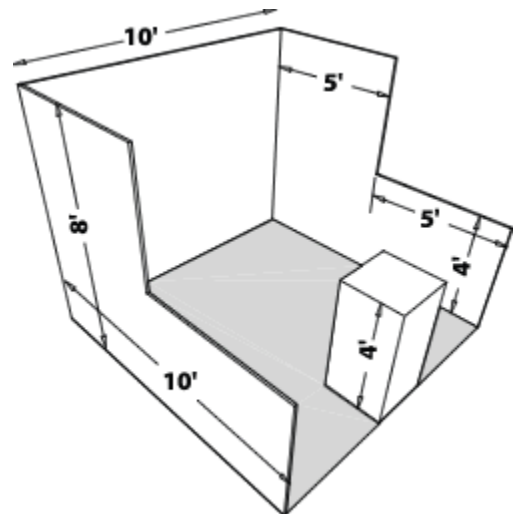

Soliciting & Canvassing *(see enclosed Rules & Regulations for more information)*

Printed advertising, souvenirs, etc. may be distributed by Exhibitors from their **booth space only**. Distribution of adhesive-backed promotional items and stickers is prohibited. Sticker removal will be at Exhibitor's expense.

Exhibitors may not canvas, solicit, or distribute literature or other promotional devices outside of their booth space.

Balloons / Popcorn Machines

Helium-filled balloons or popcorn machines are not allowed in the convention center.

Staffing the booth

The exhibitor is required to have the exhibit space staffed during all show hours.